



BEAM DETECTOR BLUE

REFLECTIVE OPTICAL BEAM SMOKE DETECTOR BLUETOOTH

MANUAL 230807



GLOBAL FIRE EQUIPMENT S.A.

Parque Industrial da Barracha, 8150-017 São Brás de Alportel - PORTUGAL • Tel: +351 289 896 560

Email: info@globalfire-equipment.com | Technical Support: techs@globalfire-equipment.com | www.globalfire-equipment.com

USER GUIDE

1 - Distance and position guidelines

These guidelines are recommendations only and it is important that you refer to your appropriate governing standards at all times. When positioning your BEAM DETECTOR there are important factors that you should consider, mainly what distance you are covering and the optimal position in the building.

What distance?

The standard BEAM DETECTOR is suitable for distances of 7m to 70m using the single reflector supplied.



NOTE: For distances under 20m use the short range mask supplied on the single reflector.

If you require 70 to 140m you will need the standard fire beam and add to it the mid range extension kit
The mid range kit comes with a backing plate and 3 extra reflectors, you will need to add the reflector from the standard kit to the mid range kit with the screws provided.



If you require 140 to 160m you will need the standard firebeam and add to it the long range extension kit
The long range kit comes with a backing plate and 8 extra reflectors, you will need to add the reflector from the standard kit to the long range kit with the screws provided.

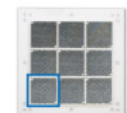

What position?

A roof is considered fat unless the height of the apex is greater than 0.6m. If the roof is fat, the BEAM DETECTOR system can be placed anywhere under the roof between 0.3m to 0.6m below the roof, up to a maximum height of 40m from the floor.

On a **Flat roof**, the firebeam has a detection area of 7.5m either side of the beam.

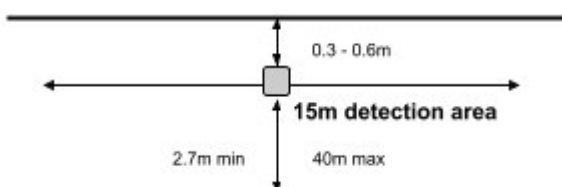

On an **Apex roof**, place the firebeam system 0.3m to 0.6m down from the top of the apex, up to a maximum height of 40m from the floor.

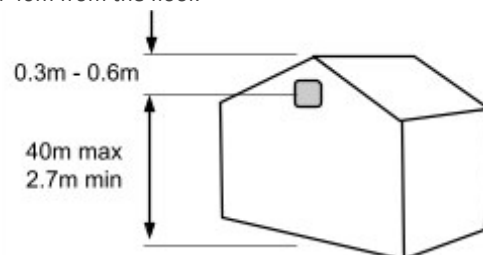

Extra coverage due to apex angle. The maximum protected area either side of the beam can be extended by 1% for every degree of roof pitch, see the example below (please check with your local regulations).

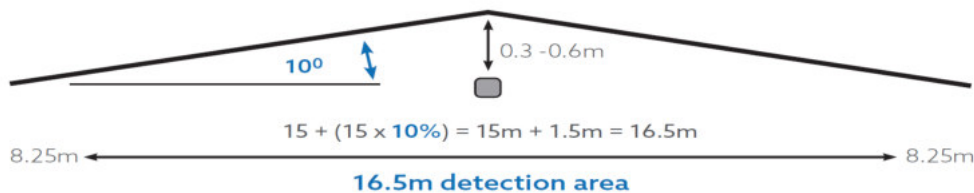

Field of view

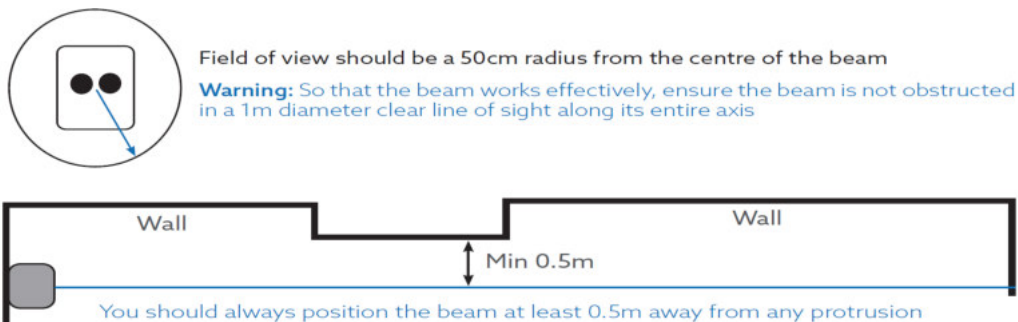

NOTE: Careful design consideration should be made when positioning beams and reflectors in environments that can be susceptible to condensation i.e. warehouses near to water that have areas open to the outside environment or that are exposed to quick extreme changes in temperature.

To assist with this problem that can affect all beam detectors we produce an anti-fog kit comprising of a specially coated reflector and lens cover. Individual reflectors are also available. The standard BEAM DETECTOR and range kits can be supplied as anti-fog sets as a special order.



2 - Installing the head

Screw the backing plate to the wall

Always try to use as sturdy a location as possible, such as brick or major structural steels (avoid mounting to outer metal cladding etc.). Avoid mounting the head where direct sunlight can shine directly into the “eyes” of the beam (care should be taken when mounting in glass atriums). Ambient sunlight will not affect the beam.

A) 2 knock-outs are provided on both sides.
Take care when using drills not to damage the circuit board. Only punch out with head open and disconnected from power.

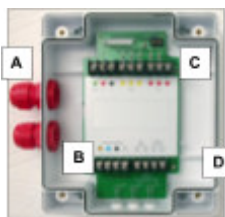

B) Wire to low level controller using bottom color coded terminals.

C) Wire into the system as required (see generic wiring diagram on the following page). Ensure that all wiring is below the level of the front edge of the box.

D) Screw in through holes provided outside of the rubber seal.

Also available - unistrut adapter plate

Use this accessory for easy mounting to unistrut fabrication. Holes are pre drilled to the correct pitch of the head and conveniently positioned for use with unistrut.

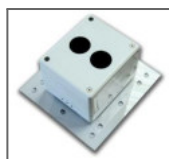

Generic wiring configurations

The Fire Beam is a conventional device. Here are the suggested wiring configurations for single and multi heads on a zone. Most wiring diagrams can be found on our website in more detail and in PDF format.

- **Brown + supply (10.2 - 30Vdc)**
- **Blue - supply (return)**
- **Black zone +**
- **Grey zone -**
- **Green earth (screen)**

Supply voltage: 12Vdc to 30Vdc normal
Quiescent current: 5.5mA
Alarm current: 5.5mA
Aligning current: normal 5.5mA fast 13.5mA
Fault/Alarm relay contact rating: 2A @30Vdc

FIRE and EOL components as supplied by the panel manufacturer.

Single head on zone

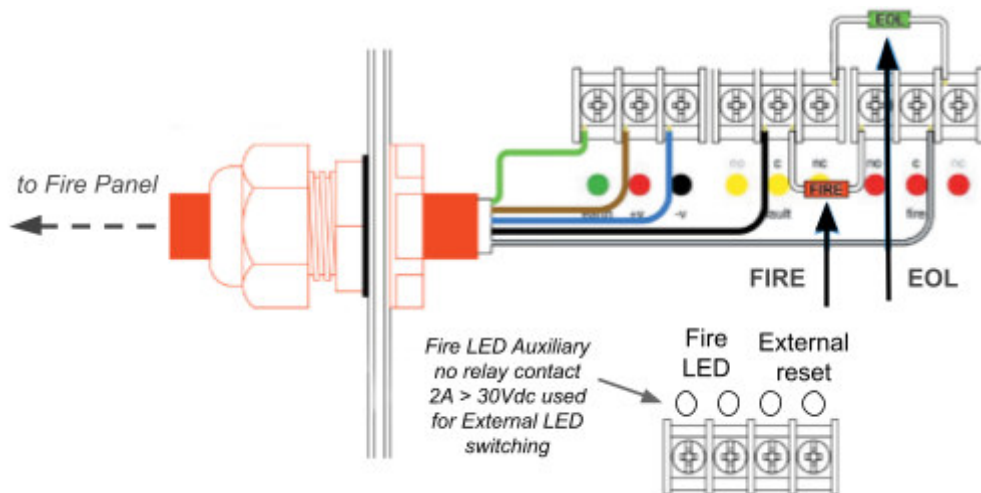

Multiple beams on a zone

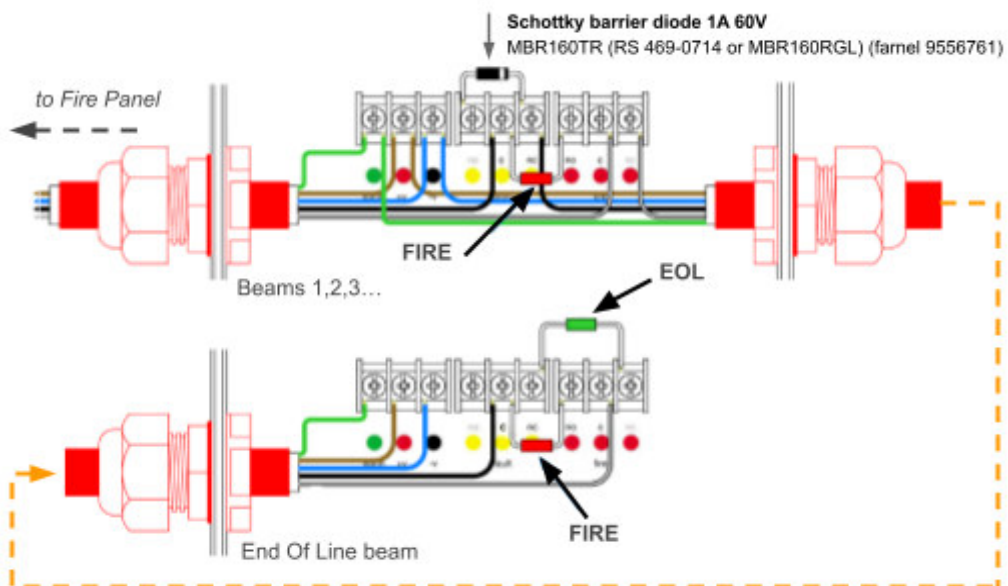

Other wiring diagrams

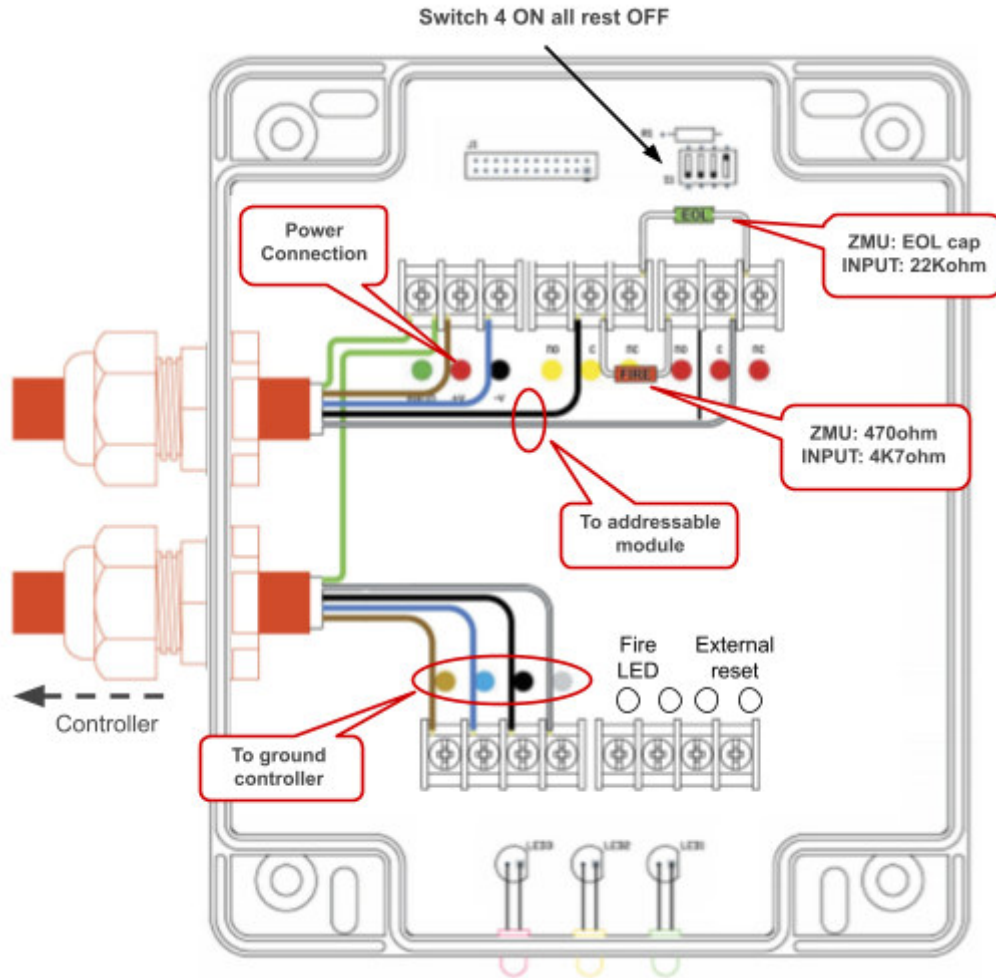

- Brown + supply (10.2 - 30Vdc)
- Blue - supply (return)
- Black zone +
- Grey zone -
- Green earth (screen)

Supply voltage: 12Vdc to 24Vdc +25% -15%
 Quiescent current: 3mA
 Alarm current: 3mA
 Aligning current: 3mA
 Fault/Alarm relay contact rating: 2A @30Vdc

FIRE and EOL components as supplied by the panel manufacturer.

IMPORTANT NOTE: When connecting the FIREBEAM detector to a GFE module, it is essential to use external power supply. The detector should not be powered directly from the addressable loop, as this may result in unstable operation, or even damage to the equipment. Therefore, it is recommended to use a separate power supply with the appropriate voltage and current rating to ensure the reliable and safe performance of the system.

ZMU and QUAD-ZMU

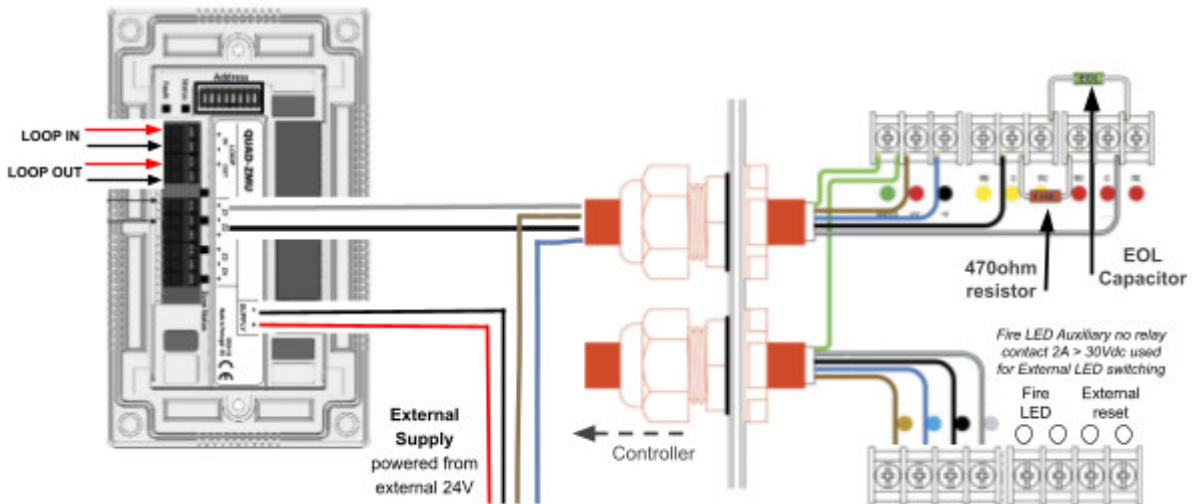
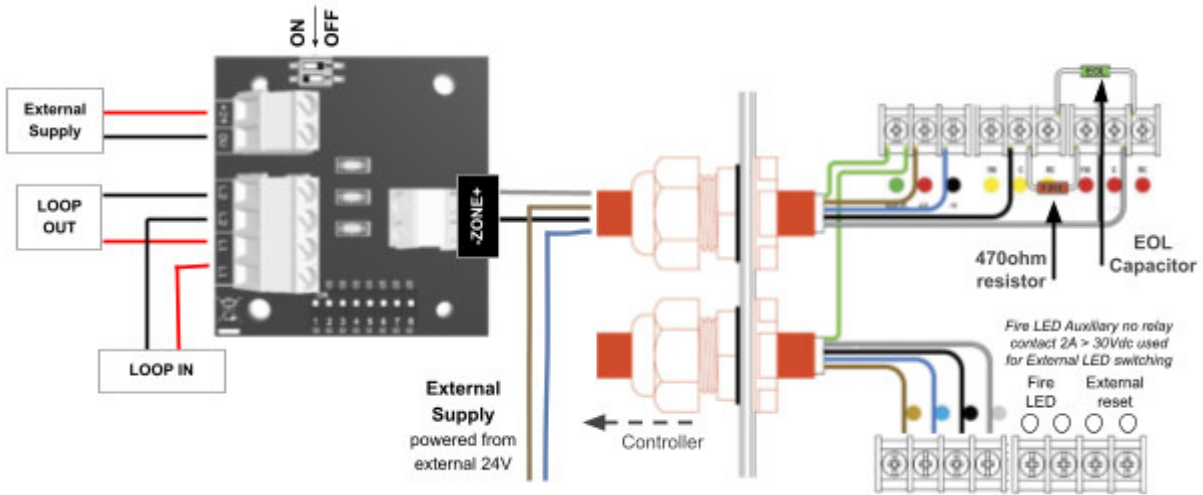

INPUT, 4/8 INPUT, I/O and 3 I/O-PLUS

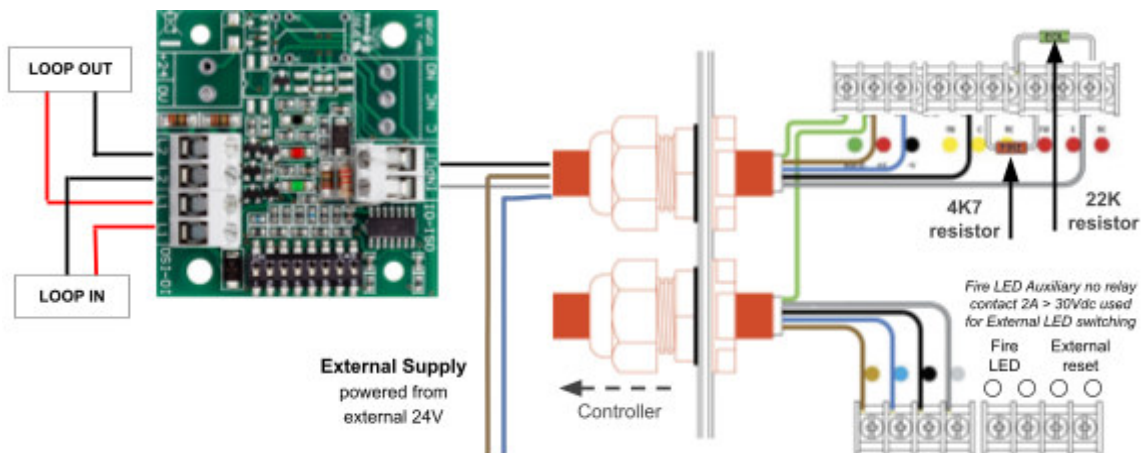



Connect the head to the base plate by first plugging in the connector. Push connector all the way so that the thumb latch is effective.

If detaching the detector head, squeeze the thumb latch and pull off the connector. To avoid straining the PCB, support the PCB whilst doing this.

if you forget to connect the head to the circuit board, the App will show **Connecting** continuously whilst trying to connect to a powered detector head. To avoid damaging the detector head, never dangle the front cover assembly from the ribbon cable.



Screw the head screws down with the 3mm allen key provided.

Your wiring should be flush and not flattened by tightening down screws.

3 - Commissioning your beam

The Fire Beam Blue is controlled by an App using your smartphone or tablet.

You must first download and purchase the Fire Beam Blue for your ANDROID or iOS device.

When installing the firebeam Blue App from the App store, you must allow Location Permission when prompted, otherwise the App cannot function.

NOTES:

To be able to **register, login or reset password**, your mobile device must have **WiFi turned on**.

For the App to be able to communicate with the beam, your mobile device must have **Bluetooth turned on**.

On smaller handsets (e.g. iPhone SE) if menus overflow the display, **reduce the text size in Settings**.

For Android and iOS devices scan the QR code below:



4 - Registering your App

Once you have downloaded the App you will need to register it.
To **register** the app enter:

- **COMPANY NAME**
- **EMAIL ADDRESS** (this is not case sensitive)
- **PASSWORD** (this is case sensitive)
- **REVIEW** fire beam's Terms and Conditions by clicking the link
- **RETURN TO THE APP** and move the slider to the right to confirm the agreement
- Press **REGISTER** (selecting Already registered? will return you to the Login menu)

You will receive a Fire Beam Blue email verification email from the Fire Beam Company.

In the email, click **VERIFY EMAIL ADDRESS** and wait for the Email verification confirmation screen to pop-up.

You will receive your Fire Beam Blue password email from the Fire Beam Company.

In the email, click **RESET YOUR PASSWORD** and in the Password Reset screen and type your new password then **SUBMIT**.

Once registered, Login by entering your **Email address** and **Password** at the Login menu and press **LOGIN**.

If you have forgotten your Password select **Reset Password** and enter **Email address** and press **Reset Password**.

You will receive a Your Fire Beam Blue password email from the Fire Beam Company. In the email, click **Reset Your Password** and in the Password Reset screen **type your new password** and **SUBMIT**.

NOTE: check your spam/junk folder if you do not immediately receive an expected Fire Beam Blue Email Verification or your Fire Beam Blue Password email.

Commissioning the Fire Beam is a simple procedure outlined in the following step by step explanation. To avoid interrupting Commissioning, do not close the App whilst Commissioning is in progress.

Ensure the installation guidelines have been followed correctly and that the Fire Beam has a clear line of sight through to the reflector and there are no obstacles in its path.

IMPORTANT DO NOT put the reflector up. However, if you are recommissioning the Fire Beam, **COVER** it with a non-reflective black cloth or similar. **You cannot commission the beam if the reflector can be seen.**



5 - LOG IN

Open the App on your device, the first screen prompts you to login. **Enter your email and password you set up when registering the App.** You can also **change to your chosen language** on this screen.



6 - STEP ONE

Connecting to a beam

Once logged in the screen you will prompt you to connect to a beam. The App will scan for devices and you will see all available powered beams seen by your device.

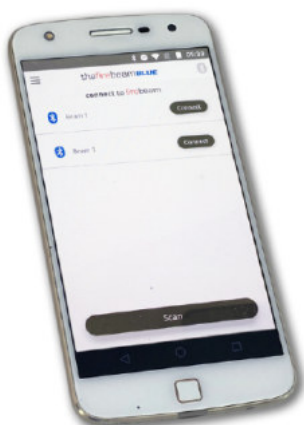

Connect to your chosen beam

Your screen will default to fire or fault with a low AQ reading. This is normal

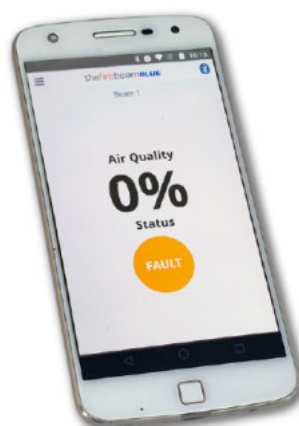

The beam you have connected to will display a BLUE FLASHING LED

This is specially useful if you have many beams in one location

6 - STEP TWO



Commissioning screen

Once logged in the screen you will prompt you to connect to a beam. The App will scan for devices and you will see all available powered beams seen by your device.

Commissioning speed

It is recommended to use **FAST** speed in commissioning (in normal speed the system uses 5.5mA, in fast speed it uses 13.5mA). Fast speed allows 4x times faster motor response and it will be quicker to commission your beam. Once commissioning is complete, the Fire Beam will automatically revert to normal speed mode (5.5mA)

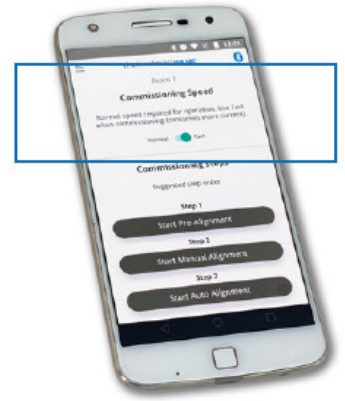

7 - STEP THREE

Commissioning - PRE ALIGNMENT

This is the most important part of setting up your beam.

Remember no reflector.

Pre-alignment sets up the amount of power you need for the distance you are covering and can indicate if you are receiving unwanted reflections from anything else in the beam path.



Press **PRE-ALIGNMENT** and the receiver sensitivity will start by raising to 100% and then the output power will then rise to 100%. More power will be output than is necessary to cover the distance and these levels will then be reduced once the auto align process takes place. The air quality figure at this point should normally stay at 0%. **At shorter distances, output power and sensitivity will rise by lesser amounts and the air quality may fluctuate or if there are unwanted reflections in the beam path.**

Press **ACCEPT PRE-ALIGNMENT** when you are happy with your pre-alignment readings.



CAUTION: If you have not allowed the 50 cm radius and the firebeam encounters an obstruction this will also stop raising the IR Power and halt the Pre Alignment as the beam will assume it has found the far wall. You will need to identify and move the obstruction or reconsider the positioning of the firebeam. You can identify that the beam is obstructed if the Air Quality rises and may fluctuate between 5%-15%

Obstructions near the head will disturb the pre-alignment process and care should be taken to ensure no solid objects are close to the beam path.

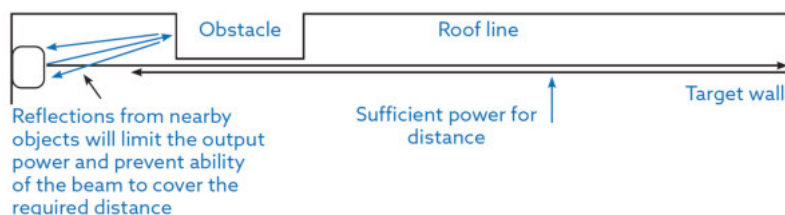

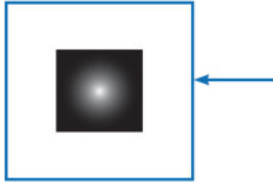

Ensure 1m of clear space along the path of the beam and 500mm from the edges of the reflector.

If the wall you are placing the reflector/s on is shiny or glass then the reflectors should be placed on a 1 meter piece of non-reflective material like MDF to ensure correct operation.

8 - STEP FOUR

Commissioning - MANUAL ALIGNMENT

Having accepted Pre-Alignment you will return to the main commissioning screen. The next stage is manual alignment. You will notice that a tick has appeared on the Pre-Alignment bar. This is to let you know you have completed this step.



Start manual alignment

NOW place or uncover the reflector

When you install or uncover the reflector the Air Quality will jump as high as 135%, this clearly shows that the Fire Beam can see the reflector.

As long as there is a received signal of at least 80 to 100% ideally over 100% you can accept Manual Alignment and move onto the next stage: Auto Alignment.



If the Fire Beam **AQ does not rise significantly** you will need to use the **Left-Right-Up-Down** keys to move the Eyes of the Fire Beam onto the reflector and once you have targeted the Fire Beam onto the reflector, the AQ will rise significantly.

In the example below we can see that the reflector is below the eyeline of the Fire Beam head, so in this case you would need to lower the angle of the beam (-Y) until you receive an AQ of over 100%

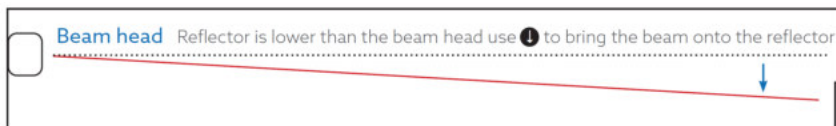

The Fire Beam can be moved on both axis to a maximum of 5 degrees. **Looking at the reflector** this will move the beam across the reflector.

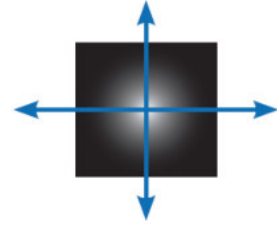

To confirm the beam is seeing the reflector covering the reflector at any time should drop the AQ and prove the beam is on the reflector.

Try and achieve as high an AQ as possible, it must be at least 80 to 100%, ideally above 100%. Once you have achieved this you can Accept Manual Alignment move onto Auto Alignment.



8 - STEP FIVE

Commissioning - AUTO ALIGNMENT

Having accepted Manual Alignment you will return to the main commissioning screen. The next stage is manual alignment. You will notice that a tick has appeared on the Manual Alignment bar. This is to let you know you have completed this step.

Start auto alignment, this is an automatic process that will firstly reduce the Receiver Sensitivity and then Output Power to accommodate the best settings for the Fire Beams environment.

The Fire Beam will automatically align to the center of the Reflector, you will notice the X and Y axis moving as the Fire Beam moves up, down, left and right to find the center point.

CAUTION: This process should take up to 10 minutes, if the Fire Beam does not complete after this time then look at the X and Y axis to check it has not deviated off the reflector onto an obstruction. The X and Y figures should be below 1.50 on each axis and would normally be below 0,90.

If this is not the case you may need to start the Manual Alignment process again to return both the Fire Beam axis to 0.00 then identify and remove any obstruction and return to Auto Alignment.

When finished, the Fire Beam will state Auto Alignment Complete and press **Done** to confirm complete Auto Alignment.



Returning to the Home screen will show.

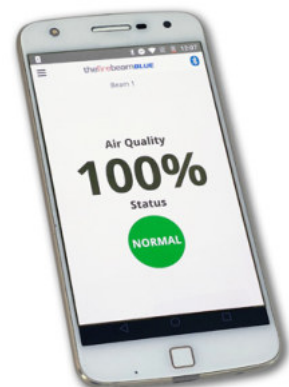

8 - STEP SIX

Commissioning - TESTING

The Fire Beam should now be tested for Fire and Fault.

The Fire Beam must be tested at the reflector end and not at the Fire Beam head.

This is to confirm it is looking at the reflector and completes the commissioning processes.

FAULT - Cover the reflector within 1 second with a non-reflective card to simulate a fault such as a fork breaking the path of the Fire Beam. After 10 seconds the Fire Beam should register **FAULT** and the Amber light will flash.

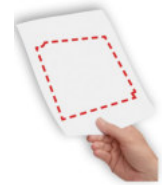

FIRE - Cover the reflector slowly up to 70% with a non-reflective card to simulate a fire such as smoke entering the path of the Fire Beam. After 10 seconds, the Fire Beam should register **FIRE** and the Red light will flash.



Once you have successfully completed both tests your Fire Beam is commissioned.

Using the menu

Now your beam is commissioned, you will be able to use the rest of the Firebeam features.

The menu system can be accessed by **SWIPING TO THE RIGHT** or by pressing the **BURGER STACK** in the top left hand corner.



The Side Draw menu contains the following items:

Home page 19

Commissioning page 20

Mode Change page 21

Maintenance page 24

Diagnostics page 25

Fire Test page 26

Connect to Firebeam page 26



Settings page 27

Explaining each menu item

HOME

Show Beam Name, Air Quality and Status

NORMAL, FIRE, FAULT, COMP, DIRT COMP LIMIT, ALIGN

NORMAL
Beam is in operation

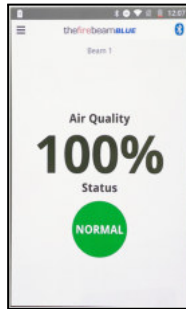

FIRE
Fire relay is triggered

Also shows if relay is latching or auto-reset

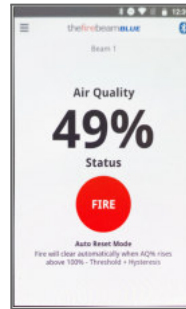

FAULT
Fault relay is triggered



COMP
Compensation has been made for dirt build-up on lenses

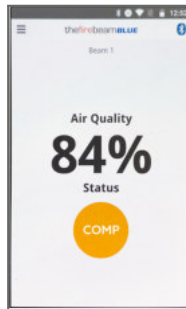

DIRT COMP LIMIT
Compensation limit has been reached



ALIGN
Beam is performing an Auto Align



Commissioning

For a full explanation of the commissioning procedure see page 12

The commissioning menu shows

BEAM NAME - Of the beam you are looking at.

COMMISSIONING SPEED - Use slider select Normal or Fast Speed. **Speed will revert to Normal when leaving the Commissioning menu.**

START PRE-ALIGNMENT - Starts Pre Alignment. **Warning - re-setting this will reset the beam to factory settings.** A tick appears when this has been performed in your commissioning procedure. The tick will disappear when you log out.

START MANUAL ALIGNMENT - Allows manual alignment. **This lets you manually move the beam path up - down - right - left.** Use this to move the beam path onto the reflector. A tick appears when this has been performed. The tick will disappear when you log out.

START AUTO ALIGNMENT - Allows manual alignment. **This lets you manually move the beam path up - down - right - left to align the beam.** A tick appears when this has been performed. The tick will disappear when you log out.

Mode Change

Here we can make changes to how the beam behaves

The APP text explains the function of each setting, here are additional notes.

THRESHOLD

The amount of obscuration needed to create a Fire Condition. Range 25-50%

Use the slider to increase or decrease the beam's sensitivity. It is factory set at 35% (meaning the received signal has to drop by 35% to trigger the fire delay. This sensitivity can be adjusted between **25% (sensitive)** and **50% (less sensitive)**.

TIME TO FIRE

In a Fire Condition, Time to Fire is the delay before Fire is signalled. Range 2-30 seconds

Adjust how long the beam has to be in fire before the fire relay is triggered. This is factory set at **10s**, you may want to increase this if there is something that may momentarily obscure the beam path (birds/forklift truck). Using the slider this can be adjusted between **2** and **30** seconds.

TIME TO FAULT

In a Fault Condition, Time to Fault is the delay before Fault is signalled. Range 2-30 seconds

Adjust the time to fault between **2** and **30** seconds (**factory set at 10 seconds**). For a beam to go into default, the beam path must be totally blocked within **ONE** second.

AUTO ALARM RESET

In Auto Alarm Reset mode Fire will clear automatically when AQ% rises above 100% - Threshold + Hysteresis
In Latching mode Beam latches in Fire until reset

The beam is factory set to auto reset when received signal raises above the fire threshold hysteresis. This can be set to latching if your system requires this.

AUTO ALIGN

Enable the beam to automatically compensate for building movement

You may want to turn the auto alignment function off, for example, in an environment that often gets filled with welding smoke or has unwanted reflections the auto align function kicks in when the received signal drops below **90%**, the point that the beam automatically checks for building movement. The beam will try to align through the smoke which could be a problem if it is unable to see the edges of the reflector. Use the slider to turn it on and off. When turning this function off, extra care should be taken to ensure that the beam head is on a sturdy fixing i.e. a brick wall or major structural steel. Auto alignment will still function in commissioning.

AUTO ALIGN TIME

Auto Align Time is the user set delay above the default 4h. Leave slider at left unless movement compensation needs to be slowed down

This is factory set to 4hrs, you can adjust this, by using the right and left keys, between 0 to 12 hours depending on your environment.

GREEN FLASH

Enables flashing of the detector head green LED to confirm power

You can turn the green flashing LED located on the head **ON** or **OFF**.

PHASE

Helps manage multiple beams in an environment to avoid cross talk. Values 0-6

When using multiple beams that **face each other** the beam output signal could phase together and can cause unreliable cross talk readings, by setting **each facing beam to a different phase number** alleviates this problem. You can choose between 0 (default setting) and 6.

HYSTERESIS

The amount by which AQ% must rise above Threshold to clear a Fire Condition. Range 1% to 40%

Changing hysteresis will change the delay in returning from a fire state back to a normal state, for example, the beam is factory set at 15% so if the beam falls into fire at 65% (35% threshold) it has to recover 15% to 80% before it returns to normal. This action prevents small fluctuations in the returned signal causing the beam to fall in and out of a fire state. This can be adjusted between **1%** and **40%**

Mode Change

Threshold
35%
The amount of obscuration needed to create a Fire Condition. Range 25-50%

Time to Fire
10s
In a Fire Condition, Time to Fire is the delay before Fire is signalled. Range 2-30 seconds

Time to Fault
10s
In a Fault Condition, Time to Fault is the delay before Fault is signalled. Range 2-30 seconds

Auto Alarm Reset
Latching Auto reset
In Auto Alarm Reset mode Fire will clear automatically when AQ% rises above 100% - Threshold + Hysteresis
In Latching mode Beam latches in Fire until reset

Auto Align
Off On
Enable the beam to automatically compensate for building movement

Auto Align Time
4h
Auto Align Time is the user set delay above the default 4h. Leave slider at left unless movement compensation needs to be slowed down

Green Flash
Off On
Enables flashing of the detector head green LED to confirm power

Phase
0 1 2 3 4 5 6
Helps manage multiple beams in an environment to avoid cross talk. Values 0-6

Hysteresis
15%
The amount by which AQ% must rise above Threshold to clear a Fire Condition. Range 1% to 40%

Maintenance

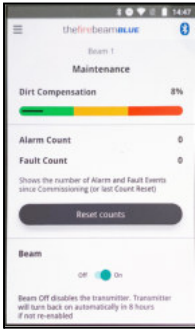

Here we can see if any compensation has been made for dust build up and whether any alarm or faults have occurred. You can also turn the beam off here.

DRIFT COMPENSATION

This screen shows how much the beam has compensated for dust build-up on the beam head and reflectors, **ALWAYS** take a note of this value as part of your routine maintenance to see any build-up pattern. A green, amber, red “traffic light” indicator will inform you when the lens and reflector need cleaning. (**once cleaned you should instigate an auto alignment to re-calibrate the beam settings**). It is possible that you may see a negative number here, this can happen when the beam has been commissioned in a “dirty” atmosphere such as builders dust which, once cleared, the beam then compensates for this.



ALARM AND FAULT COUNT

Here we can see how many times the beam has gone into fire or fault since the beam was commissioned or since the event log was last cleared including testing. You can also reset the counts here.

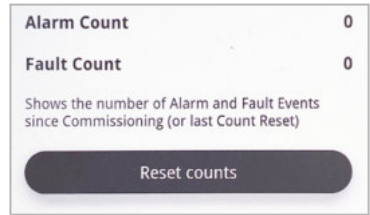

BEAM ON - OFF

If you may need to turn the beam off, it can be turned OFF and ON here. **Turning off will show as a fault on the panel.**

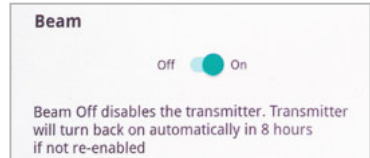

Diagnostics

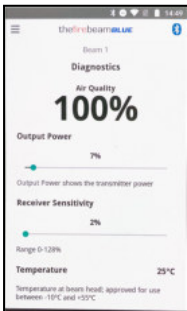

Here we can see, monitor and adjust the output power and the receiver sensitivity. We can also see the temperature at the beam head

OUTPUT POWER

This shows the amount of Output Power that is being transmitted. It can be increased or decreased by using the slider.

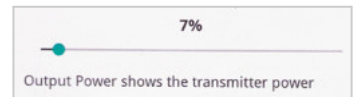

RECEIVER SENSITIVITY

Here shows the receiver sensitivity and can be changed by using the slider. The range is between 0 & 128%

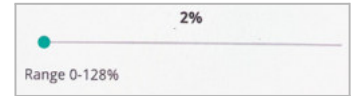

NOTE: By changing the **Output Power** or **Receiver Sensitivity** you are changing a commissioned beam setting. It is advisable to **retest your beam** to check suitability of any changes made.

TEMPERATURE

The temperature shown is at the beam head. The beam is approved between -10°C and +55°C

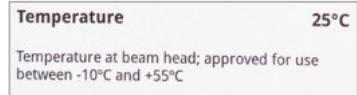

Fire test

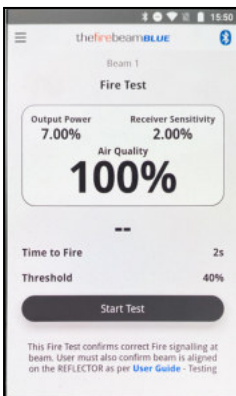

A fire test can be performed here to test correct signaling at the beam and Panel



FIRE TEST

Press **start test** to perform a fire test, this works by running a test algorithm to lower the output power, the receiver sees this as obscuration. When the receiver signal drops **below** the threshold point the beam will trip the fire relay - **this relay will not trip until the time to fire has passed which could be anything between 2 and 30 seconds.**

Connect to Firebeam

You use this screen to scan and connect to your beam of choice.

Pressing **Scan** will reveal all the Firebeams within range.

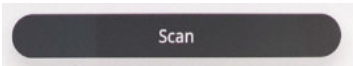

Press **Connect** to communicate with your chosen beam. This will take you back to the Home Screen for that beam.

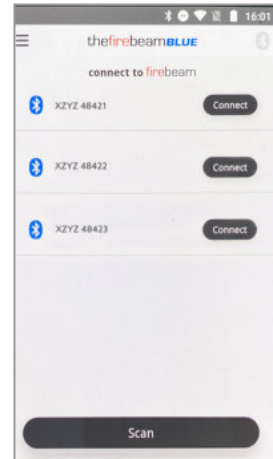
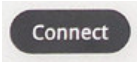

DISCONNECT

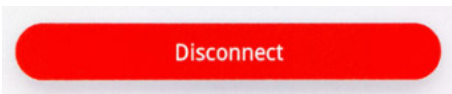

When you have finished working on your beam simply return to the connect menu and press disconnect. This will return you to the connect to beam screen. From here you can select another beam to work with.

NOTES: To allow another mobile device to find the powered beam, **the App should be disconnected once the beam has been commissioned.** The App is not used during operation of the beam, only commissioning.

Settings

You use this screen to change your language choice, change a beam's name and log out.

LANGUAGES

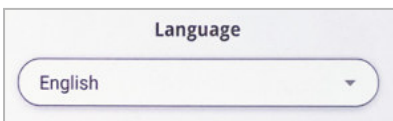

The default setting is English. You can change the language to your own choice here.

CHANGE FRIENDLY NAME

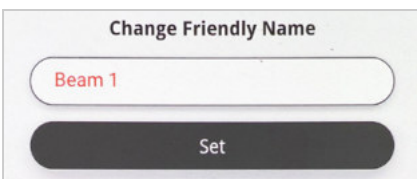

Change the beam name here by keying in a new name. Press Set to confirm your choice.

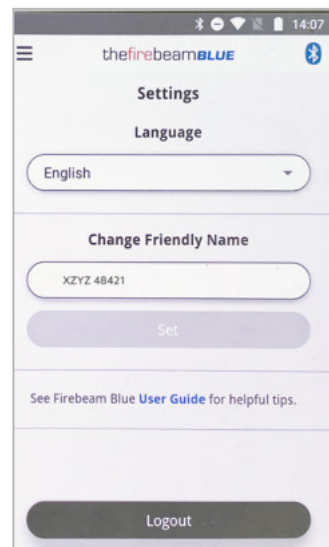

TECHNICAL SPECIFICATIONS

<p>ELECTRICAL SPECIFICATIONS Supply Voltage 12 to 30 Vdc normal Supply Current 5.5mA in all operational states Supply Current 13.5mA in fast commissioning</p>	<p>ALARM INDICATION App Status - FIRE Head Red Flashing LED Alarm Relay Change Over (CO) Contact Rating 2A @ 30Vdc</p>	<p>REGULATORY INFORMATION</p> 
<p>ENVIRONMENTAL SPECIFICATIONS Temperature -10°C to +55°C Humidity 10 to 95% RH Non-condensing Protection Index IP65 when suitably mounted and terminated</p>	<p>TEST/RESET FEATURES Beam test function with App Alarm latching/auto-reset selectable (default auto-reset) Alarm reset in latching mode with App reset function, removing power for > 5 seconds or momentarily apply > 5 VDC to reset connections in Beam Head</p>	<p>EN54-12 Line-type smoke detector: Firebeam Blue is intended for use in fire detection and fire alarm systems in buildings OPERATIONAL RELIABILITY: Individual alarm indication: Red LED Connection of ancillary devices: Correct operation Manufacturer's adjustments: Special means required On-site adjustment of response value: Special means required Protection against ingress of foreign bodies: Protected (>1.3mm) Monitoring of detachable detectors and connections: Fault signal released Requirements for software-controlled detectors: Documentation, design and storage correct NOMINAL ACTIVATION CONDITIONS/SENSITIVITY: Reproducibility: Cmin >= 0.4dB, Cmax/Crep <= 1.33; Crep/Cmin <= 1.5 Repeatability: Correct operation, Cmin >= 0.4dB; Cmax/Cmin <=1.6 Tolerance to beam misalignment: Maximum angle >0.4° Rapid changes in attenuation: Correct operation Response to slowly developing fires: Correct operation</p>
<p>MECHANICAL SPECIFICATIONS Beam head 180mmH x 155mmW x 137mmD, weight 1.1 Kg 70KIT140 Mid-Range Reflector 293mmH x 293mmW x 5mmD weight 0.8Kg 140KIT160 Long Range Reflector 394mmH x 394mmW x 5mmD weight 1.8Kg Adapter 270mmH x 250mmW x 5mmD weight 0.6kg (mounts the Beam Head onto unistrut)</p>	<p>FAULT SENSITIVITY LEVEL <4% FAULT CONDITION Obscuration drops to below the fault sensitivity level within 1 second Power Down or Supply Voltage < 9Vdc Commissioning modes, Pre-Alignment and Auto Alignment Beam turned off during Beam Maintenance Time to Fault Condition adjustable, 2 to 60 seconds in 1 second increments (default 10 seconds) FAULT INDICATION App Status - FAULT Head yellow flashing LED 1 second Fault Relay Change Over (CO) Contact Rating 2A @ 30 Vdc</p>	<p>Response to slowly developing fires: Correct operation Optical path length dependence: Cmin >=0.4dB; Cmax/Cmin <=1.6 Stray light: Correct operation: Cmin >=0.4dB; Cmax/Cmin <=1.6 TOLERANCE TO SUPPLY VOLTAGE: Variation in supply parameters: Cmin >=0.4dB; Cmax/Cmin <=1.6 Performance under fire conditions: Fire sensitivity: ma < 0.7dB m-1 DURABILITY OF NOMINAL ACTIVATION CONDITIONS/SENSITIVITY: TEMPERATURE RESISTANCE Dry heat (operational): Correct operation, Cmin >=0.4dB; Cmax/Cmin <=1.6 Cold (operational): Correct operation, Cmin >=0.4dB; Cmax/Cmin <=1.6 HUMIDITY RESISTANCE Damp heat, steady state (operational): Correct operation, Cmin >=0.4dB; Cmax/Cmin <=1.6 Damp heat, steady state (endurance): Cmin >=0.4dB; Cmax/Cmin <=1.6 VIBRATION RESISTANCE Vibration (endurance): Cmin >=0.4dB; Cmax/Cmin <=1.6 Impact (operational): Correct operation, Cmin >=0.4dB; Cmax/Cmin <=1.6 ELECTRICAL STABILITY EMC Immunity tests (operational): Correct operation, Cmin >=0.4dB; Cmax/Cmin <=1.6 CORROSION RESISTANCE Sulfur dioxide (SO2) corrosion (endurance): Cmin >=0.4dB; Cmax/Cmin <=1.6</p>
<p>OPTICAL SPECIFICATIONS Optical wavelength 870 nm Maximum Angular Alignment +-5° Maximum Angular Misalignment (static non auto-alignment) Beam head +-0.4° Reflector +-2°</p>	<p>NORMAL CONDITION Obscuration level is above the Alarm sensitivity level App Status - NORMAL Programmable ON/OFF Head Green Flashing LED Programmable ON/OFF</p>	
<p>OPERATION SPECIFICATIONS Protection Range</p> <p>FIREBEAM Standard product 7 to 10 meters. Use a short range mask for distances between 7 & 20 meters.</p> <p>70KIT140 Mid-range reflector kit 70 to 140 meters</p> <p>140KIT160 Long-range reflector kit 140 to 160 meters</p> <p>Alarm Sensitivity Levels 25% (1.25dB) to 50% (0.05dB) increments (Default 35% (1.87dB)) Alarm condition Obscuration drops to below pre-defined sensitivity level. Time to Alarm Condition adjustable 2 to 30 seconds in 1 second increments (default 10 seconds)</p>	<p>AUTO-ALIGN/BEAM CONTAMINATION COMPENSATION Auto-align during normal operation if obscuration drops below 90% for the duration of the align time set (does not affect normal operating mode) Beam contamination Compensation 4 Hour monitoring. Compensation data available in the App</p>	



GLOBAL FIRE EQUIPMENT S.A.

Parque Industrial da Barracha, 8150-017 São Brás de Alportel - PORTUGAL • Tel: +351 289 896 560

Sales: sales@globalfire-equipment.com • **Technical Support:** techs@globalfire-equipment.com • **www.** globalfire-equipment.com
