

DMN700R

Conventional MCP, Flush Mount, Red, 560Ω & Free Contact With Glass

General

Installation efficiency, flexibility and full compliance with the latest standards are at the heart of the new MCP indoor call point range.

Installation

Installation time and ultimately cost, are of paramount importance. The MCP range directly reflects this need by providing a unique 'plug and play' concept designed specifically to reduce installation time. All new MCP products utilize a special terminal block, where all initial installation cabling is terminated. This terminal block is then simply connected to the back of the MCP. Simple, but effective, with no re-termination required and no time wasted.

Options and approvals

Through new standards and legislation, both break glass and re-settable operating elements may now be used. To provide the greatest 'flex-ability', the new MCP range can be configured as either a break glass or re-settable unit by simply changing from one element to another. No other additional parts or alternative products are required.

Full compliance with the latest standards is essential and the new MCP indoor call point range is fully approved to the latest EN54-11 standard



Details

- Enhanced aesthetics
- 'Plug & Play' installation concept
- Surface mount option available
- Protection hinged cover with anti-tamper facility available
- Built in resistor or potential free, change-over contacts provides backward compatibility options to any conventional systems
- Key test facility avoids breaking the glass during testing
- Resettable element available as alternative for the frangible (glass) element
- Easy to replace glass
- High quality micro switch ensures maximum reliability
- Fully approved to the latest standards

DMN700R

Conventional MCP, Flush Mount, Red, 560Ω & Free Contact With Glass

Technical specifications

General

Status indication	Flag
Compatibility	Conventional zones

Electrical

Operating voltage	30 VDC (Max)
Cable specification	0.5 - 2.5 mm ²
No. of cable cores	2
Terminals	3

Detection

Detection principle	Switch
Max. contact rating (resistive load)	2A @ 30 VDC

Physical

Physical dimensions	89 x 93 x 27.5 mm
Net weight	130 g
Colour	Red (RAL 3001)
Mounting type	Recessed mount
Cable entries	1 (Rear)
Material (body)	PC/ABS
Functional marking	House on Fire

Environmental

Vandal proof	No
Operating temperature	-10 to +55°C
Storage temperature	-10 to +55°C
Relative humidity	93± 3% non-condensing
Environment	Indoor
IP rating	IP24D

Regulatory

Compliance	CE, REACH, RoHS 2
Certification	EN54-11
Standards	EN54-11

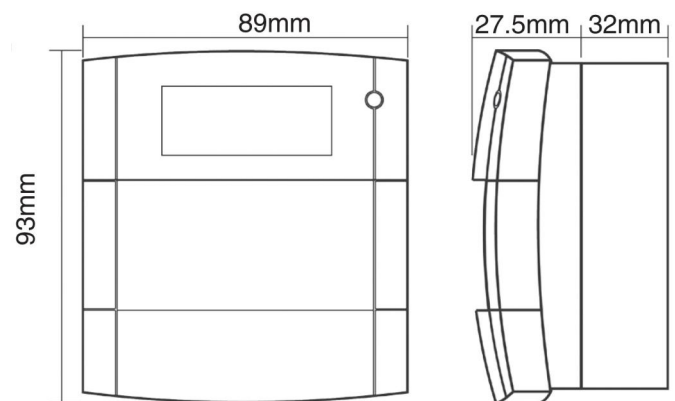

As a company of innovation, Carrier Fire & Security reserves the right to change product specifications without notice. For the latest product specifications, visit firesecurityproducts.com online or contact your sales representative.

Last updated on 17 August 2022 - 15:53