



## CZ-EMM2

### PROXIMITY CARD READER

cz\_emm2\_en 12/19

CZ-EMM2 reader is designed to read the unique codes of the users' proximity cards. The reader can be connected to:

- INT-R universal expander for card / iButton readers (if used as the CA-64 SR expander),
- ACCO-KP / ACCO-KP-PS / ACCO-KPWG / ACCO-KPWG-PS access control module.

## 1. Features

- Support for cards, tags and other 125 kHz passive transponders.
- Data format: EM-Marin.
- Bi-color LED.
- Built-in sounder.

## 2. Description

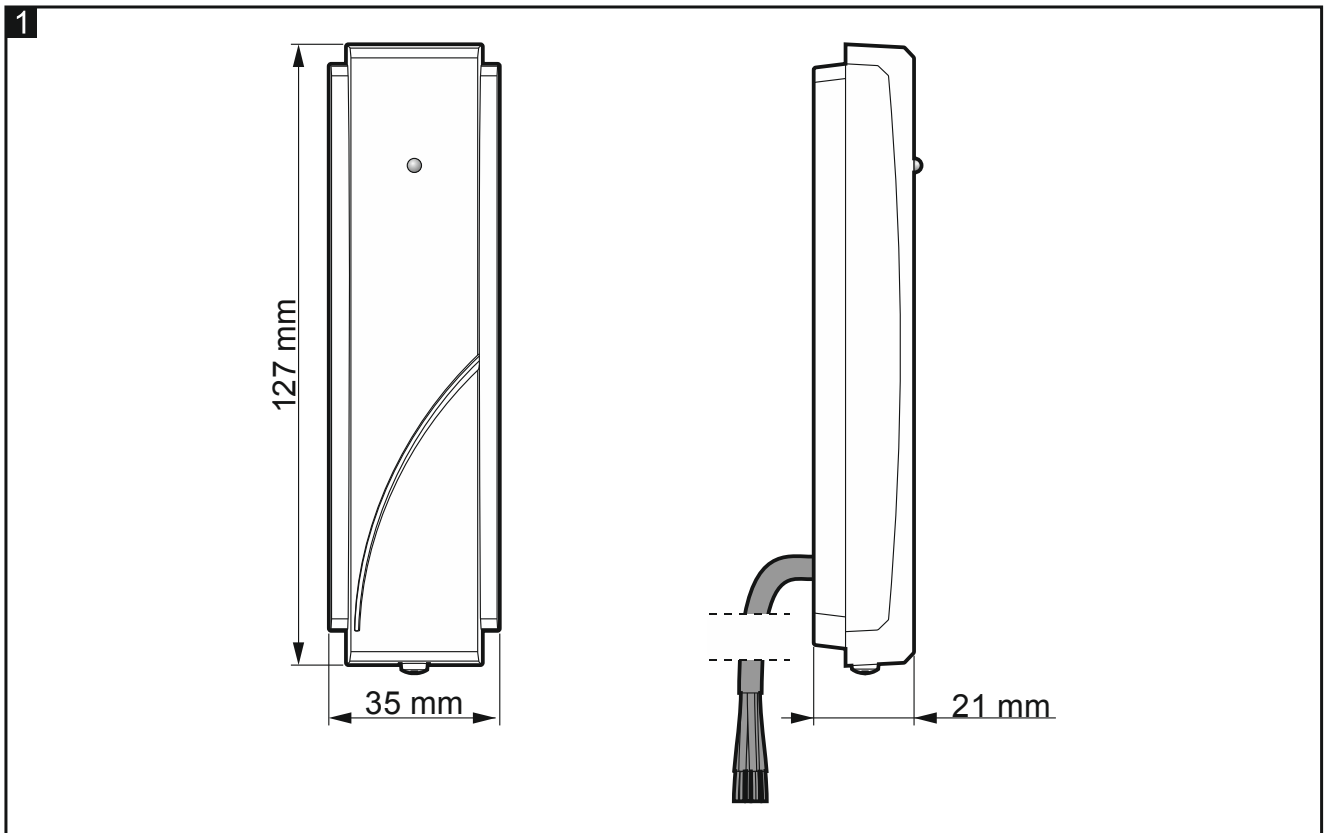

The electronic circuit is potted in epoxy resin for protection against moisture and dust. The multi-conductor cable is led-out of the reader enclosure.

The LED indicator and audible signal are controlled by the device the reader is connected to. The LED is red and green.

### 3. Installation



**The device should be installed by qualified personnel.**

**Disconnect power before making any electrical connections.**

The reader is designed for indoor installation.



*The reader should not be exposed to direct contact with water.*

*If the reader is installed on a metal surface, the card reading range will be reduced.*

*Two readers connected to the same device can work when situated a short distance from each other. However, the distance from a reader connected to another device or a device with built-in reader (e.g. a keypad with reader) should be at least 50 centimeters.*





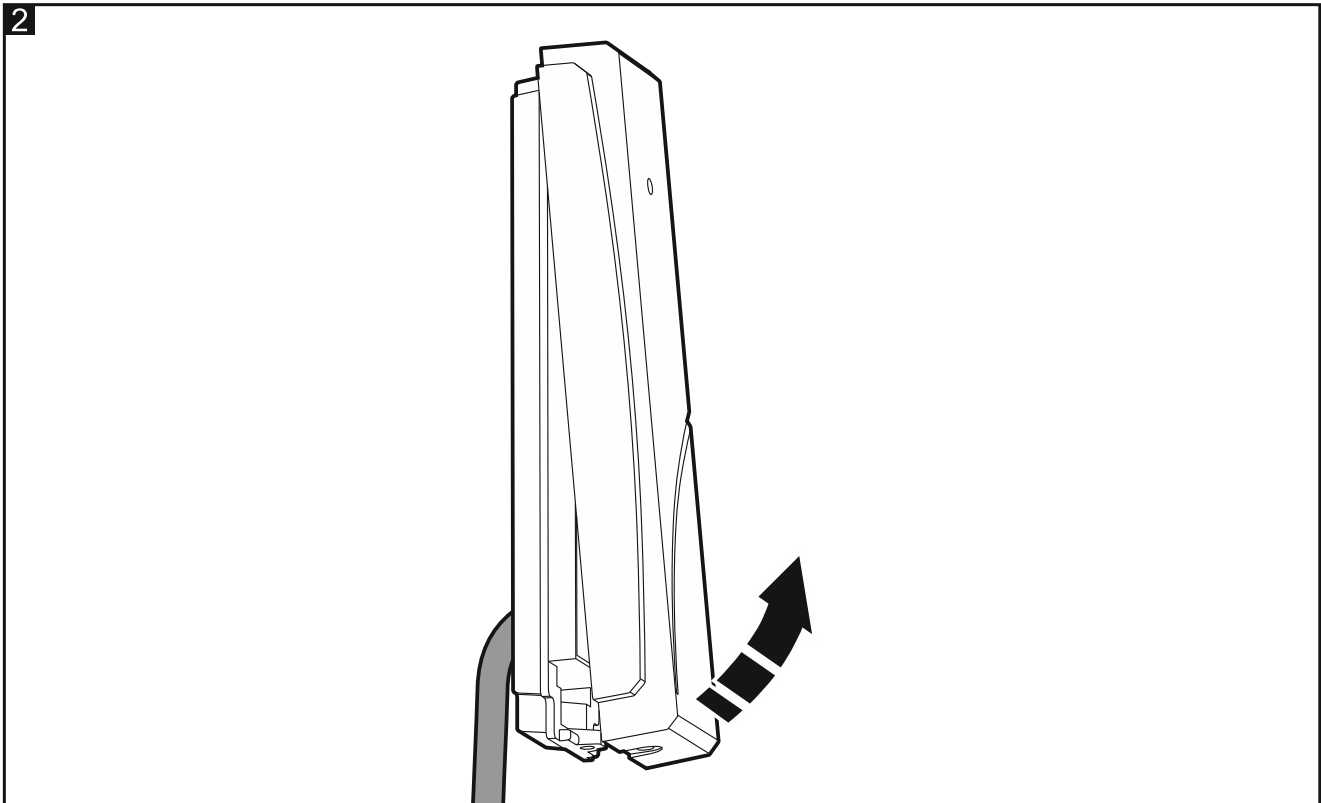



If you need an extra cable to make the connections, use an unshielded non-twisted cable. The total length of the cable connecting the reader to the device should not exceed 30 meters.

1. Remove the reader cover (Fig. 2).



2. Place the enclosure base against the wall and mark the location of mounting holes.
3. Drill holes for wall plugs (anchors) in the wall.
4. Make a hole in the wall for the reader cable and run the cable through it.
5. Using wall plugs (anchors) and screws, secure the enclosure base to the wall. Select wall plugs specifically intended for the mounting surface (different for concrete or brick wall, different for plaster wall, etc.).
6. Replace the cover and secure it with the screw.

7. Connect the wires to the device screw terminals according to the table below.

Wire	Description	Terminals	
		Reader A	Reader B
 red	power	+GA	+GB
 green	data	SIGA / SIG1A	SIGB / SIG1B
 blue	common ground	COM	COM
 yellow	sounder	BPA	BPB
 pink	LED green color	LD1A	LD1B
 gray	LED red color	LD2A	LD2B
 brown	blocking reader operation	DISA	DISB
 white	presence control	TMPA	TMPB

## 4. Using

Present the card to the reader so that the reader can read the card code. The card code will be sent to the device to which the reader is connected. That device will decide what function to run.

The device to which the reader is connected can distinguish between presenting the card (one-time reading the card code) and holding the card (the card must be held in front of the reader for about 3 seconds, and its code will be read repeatedly during that time). Another function can be activated by presenting the card, and another by holding it.

The way the visual (LED) and audible (sounder) signaling works depends on the device to which the reader is connected.

## 5. Specifications

Supply voltage .....	12 VDC $\pm$ 15%
Maximum current consumption .....	55 mA
Reader transmit frequency .....	125 kHz
Operating temperature range .....	+5°C...+40°C
Maximum humidity .....	93 $\pm$ 3%
Dimensions .....	35 x 127 x 21 mm
Weight .....	72 g

The declaration of conformity may be consulted at [www.satel.eu/ce](http://www.satel.eu/ce)