

CE 1471

ASP-105

WIRELESSLY TRIGGERED OUTDOOR SIREN

asp105_en 05/16

The ASP-105 siren provides information about alarm situations by means of optical and acoustic signaling. The siren is designed for operation within the ABAX two-way wireless system. This manual applies to the siren with electronics version 1.3D and firmware version 3.01 (or newer).

1. Features

- Acoustic signaling by means of piezoelectric transducer.
- Optical signaling by means of LEDs.
- Remote configuring.
- Powered with +12 V DC.
- Backup battery.
- Weatherproofed electronic circuit.
- Tamper protection against cover removal and tearing enclosure from the wall.
- High-impact polycarbonate enclosure, featuring a very high mechanical strength.

2. Specifications

Operating frequency band	868.0 MHz ÷ 868.6 MHz
Radio communication range (in open area)	up to 500 m
Supply voltage	12 V DC ±15%
Backup lead-acid battery	6 V/1.2 Ah
Standby current consumption (with fully charged battery)	30 mA
Maximum current consumption (with fully charged battery):	
optical signaling	80 mA
acoustic signaling	225 mA
optical and acoustic signaling	265 mA
Sound pressure level (at 1 m distance)	up to 120 dB
Security grade according to EN 50131-4	Grade 2
Environmental class according to EN50130-5	IV
Operating temperature range	-25°C ...+70°C
Maximum humidity	93±3%
Spełniane normy	EN 50130-4, EN 50130-5, EN 50131-1, EN 50131-4, EN 50131-5-3
Dimensions	148 x 254 x 64 mm
Weight	1010 g
Name of certification body	Telefication

Notes:

- *The battery charging current depends on the battery degree of discharge.*
- *The built-in battery charging circuit is designed for recharging a partially discharged battery, not for charging a fully discharged one.*

Hereby, SATEL sp. z o.o., declares that this siren is in compliance with the essential requirements and other relevant provisions of Directive 1999/5/EC. The declaration of conformity may be consulted at www.satel.eu/ce

3. Description

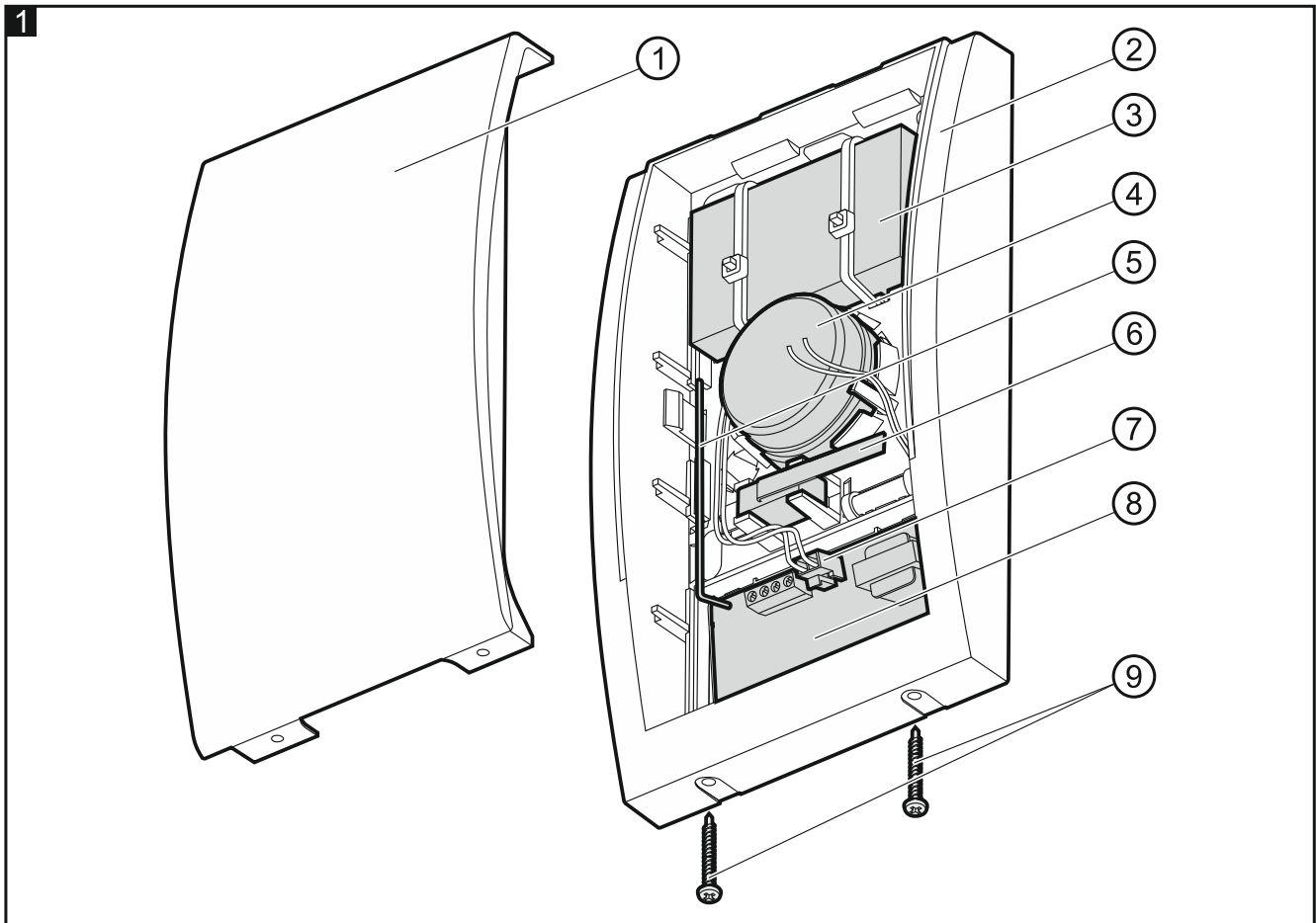

Explanations for Fig. 1:

- ① enclosure cover.
- ② enclosure base.
- ③ battery.
- ④ piezoelectric transducer.
- ⑤ antenna.
- ⚠ **Never shorten or deform the antenna.**
- ⑥ tamper switch (tamper alarm triggered if open).
- ⑦ battery connector.
- ⑧ electronics board.
- ⑨ cover locking screws.

Triggering the alarm signaling

The alarm signaling is triggered:

- on receiving the start signaling command – the optical and acoustic signaling can be triggered independently of each other. Duration of the optical signaling is not limited (the alarm will last until the end signaling command is received). Maximum duration of the acoustic signaling must be defined when configuring the siren.
- on opening the tamper switch – both optical and acoustic signaling is triggered. The signaling will last for the maximum duration of the acoustic signaling preset for the siren. Opening the tamper switch will not trigger any signal:
 - for 40 seconds after power-on,
 - when the ABAX system is running in test mode,

– when the control panel is running in service mode.

There can be a few seconds' delay between starting the test mode / service mode and blocking the tamper signaling.

When the tamper signaling is blocked, the red LED is blinking every 3 seconds.



1	Two sound frequencies (1450 Hz/2000 Hz) alternating within 1 second	
2	Sound with smoothly rising and falling frequency (1450 Hz – 2000 Hz – 1450 Hz) within 1 second	
3	Sound with rising frequency (from 1450 Hz to 2000 Hz) within 1 second	
4	Sound with falling frequency (from 2000 Hz to 1450 Hz) within 1 second	

Table 1. Tone types for acoustic signaling.

Main power supply

The siren must be supplied with 12 V DC \pm 15% voltage. If the 12 V DC supply is lost, the siren will report it during polling.

Backup power supply

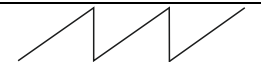
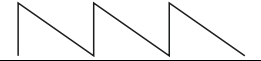
A 6 V / 1,2 Ah lead-acid battery is used as a backup power supply. If the battery voltage drops below 5.7 V, the siren will report low battery during polling. The battery is tested only when the siren is powered from the battery, so its status must be checked when maintenance work is being performed.

Terminals

TMP - tamper input. The tamper switch (NC) is connected to the terminals.

+12V - +12 V DC (\pm 15%) power input.

COM - common ground.

Enclosure base

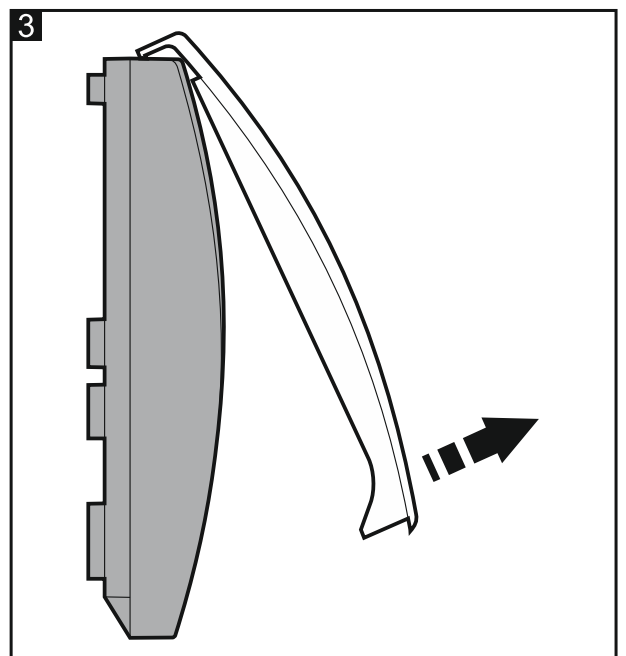
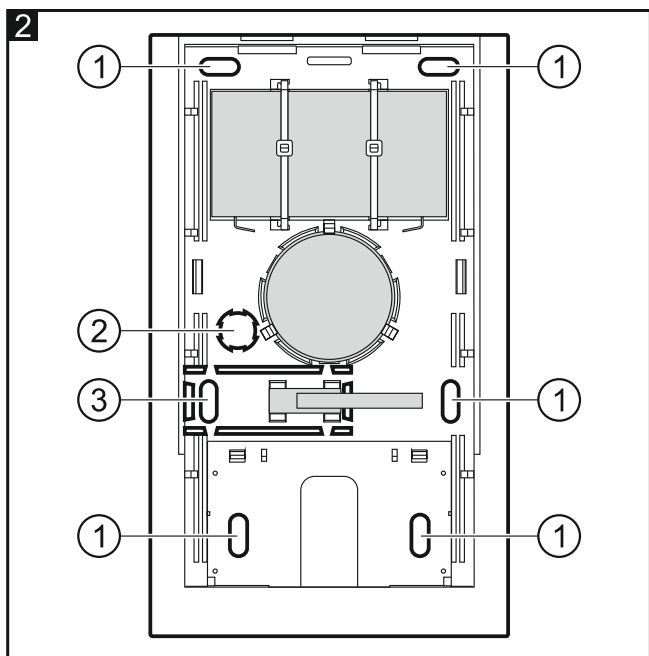

Explanations for Fig. 2:

- ① mounting hole.
- ② cable entry hole.
- ③ tamper mounting hole.

4. Installation and start-up

The siren must be installed on the wall, high above the floor, at a hard to access location, so as to minimize the risk of tampering. Make sure that some free space is left above the siren (at least 2.5 cm). Otherwise, it will be impossible to replace the cover.

1. Remove the cover locking screws.
2. Lift up the enclosure cover by approx. 60° and remove it (see Fig. 3).
3. Connect the battery to the dedicated leads (positive terminal to RED lead, negative terminal to BLACK lead).
4. Add the siren to the wireless system (see the ABAX controller manual or the INTEGRA 128-WRL / VERSA / VERSA Plus / VERSA IP control panel installer manual). The sticker with serial number which shall be entered when registering the siren in the system can be found on the electronics board.
5. Replace the siren cover.
6. Fasten the siren temporarily at the place of its future installation.
7. Check the level of signal received from the siren by the ACU-120 / ACU-270 controller or the INTEGRA 128-WRL control panel. If the signal level is lower than 40%, select another place for installation. Sometimes, it is sufficient to shift the device ten or twenty centimeters to obtain a considerable improvement in the signal quality.
8. Remove the siren cover.
9. Disconnect the battery.
10. Move aside the catches holding the electronics board and remove it.
11. Place the enclosure base on the wall and mark the location of mounting holes (see Fig. 2). Be sure to take into account the tamper mounting hole.
12. Drill the holes for wall plugs (screw anchors).
13. Run the power wires through the hole in the enclosure base (see Fig. 2).
14. Secure the enclosure base to the wall with wall plugs (screw anchors) and screws. Remember about the tamper mounting hole. The wall plugs (screw anchors) and screws delivered with the siren are intended for brick, concrete and similar mounting surfaces. For other surfaces (e.g. drywall, wood, styrofoam), use other wall plugs (screw anchors), as required.
15. Secure the electronics board in the enclosure base.
16. Connect the battery to the dedicated leads.
17. Secure the power wires in screw terminals on the electronics board.
18. Replace the siren cover and fasten it with screws.
19. Configure the siren (e.g. define the maximum duration of acoustic signaling and the type of acoustic signaling). For detailed information on how to configure the siren, refer to the controller / control panel manual.