

They are intended for indoor use within Intrinsically Safe (I.S.) Systems utilising suitable Safety Barriers.

### Special conditions for safe use (denoted by X after the certificate number)

The enclosure is non-conducting and may generate an ignition-capable level of electrostatic charges under certain extreme conditions. The user should ensure that the equipment is not installed in a location where it may be subjected to external conditions (such as high-pressure steam) which might cause a build-up of electrostatic charges on non-conducting surfaces. Additionally, cleaning of the equipment should be done only with a damp cloth.

These call points must not be modified in any way as doing so may invalidate the Certification and may compromise the safety of the product.



## Conventional I.S. Outdoor Manual Call Point Installation Guide

### General

The Conventional I.S. Outdoor Manual Call Point is available in two versions:

Part Number	Model Number	Product Name
55100-033	WCP1A-R470SF-A071-01IS	Conventional I.S. Outdoor Manual Call Point-Red
55100-034	WCP1A-Y470SF-A071-01IS	Conventional I.S. Outdoor Manual Call Point-Yellow

### Installation

- Fit the backbox to a flat surface using the three fixing holes and screws provided. The cable entry holes should be in the vertical plane. The backbox can be mounted with either the single or double entry holes at the top.(Fig 1).  
*Note: Cable entry from the bottom of the call point is recommended if there is a possibility of moisture condensing within the conduit or cables.*
- Remove terminal block from the PCB. Run the cables into the backbox and connect them to the terminal block as shown in Fig 2. Ensure that functional earth/screen continuity is maintained. Screens should be connected to the terminal in the backbox.
- Reconnect the terminal block to the PCB and ensure that the O-ring is correctly seated in its channel. Place the cover squarely over the backbox and carefully push the cover until the locating clips have engaged, use the 4 fixing screws to lock the cover in place. **Do not use excessive force, do not over tighten screws.**
- To remove the cover, undo and remove the four cover fixing screws. The four retaining clips also need to be released. To do this place a flat bladed screwdriver into the slot between the cover and backbox and gently twist until the clip disengages (Fig 3). Repeat this for the three remaining clips and pull the cover away from the backbox.

The call points should be installed in a position where they will not be subjected to mechanical stresses and where the temperature is within operating temperature range. Areas where there are, or are likely to be, aggressive substances should be avoided.

The Conventional I.S. Outdoor Manual Call Point is a 'type A' call point and is suitable for outdoor use.

### Wiring Details

To maintain the integrity of the enclosure it is essential that suitable IP67 cable glands be used.

### Technical Data

Maximum Voltage	30V
Maximum Switching Current	500mA
Alarm Resistor	470 Ω
IP rating	IP67
Operating Temperature	-25°C to 70°C (see approvals)
Wattage	1W

### EC Declaration of Conformity

KAC ALARM COMPANY LTD declares that the products identified below conform to the essential requirements that have been specified in the European Directive on Equipment and Protective Systems Intended for use in Explosive Atmospheres 94/9/EC. This Directive has been enacted into UK law by the statutory Instrument No. 1996/192. The Equipment and Protective Systems Intended for use in Explosive Atmospheres Regulations 1996.

**Product Type – Outdoor surface / flush mounting intrinsically safe conventional call point for use in fire detection and alarm systems.**

**Product Range –** Intrinsically safe variants of the following product groups denoted by 'IS' in the part code and marked in accordance with the ATEX requirements.

**WCP1A, WCP2A, WCP3A, WCP4A, WCP7A**

This product range is manufactured by KAC Alarm Company Ltd at their premises; KAC House, Thornhill Road, North Moons Moat, Redditch, B98 9ND.

An EC Type Examination Certificate has been granted for this product range by the Notified Body Sira Test and Certification Ltd, Rake Lane, Eccleston, Chester, CH4 9JN. The identification number of this Notified Body is 0518.

EC-Type Examination Certificate Number: **SIRA 06ATEX2131X**

This product range is certified to the following standards;

EN60079-0:2006	EN 61241-0:2006
EN60079-26:2007	IEC 61241-11:2005
EN60079-11:2007	

These products meet the Essential Health & Safety Requirements of the above standards. Additional EHSRs have been identified and individually assessed in report R52A18973A.

This declaration is made for and behalf of KAC Alarm Company Ltd by the responsible person below who is authorised by KAC to make such a declaration.

Signature: Ian Garden QHSE Manager  
Date of Issue 3 December 2008

KAC Alarm Company Limited  
KAC House, Thornhill Road, North Moons Moat,  
Redditch, Worcestershire B98 9ND

D 971 -1

## Commissioning

The installation must conform to BS5839-1 (or applicable local codes).

Ensure that the deformable element is fitted to each call point before testing. Use the test key provided to check the operation of each device.

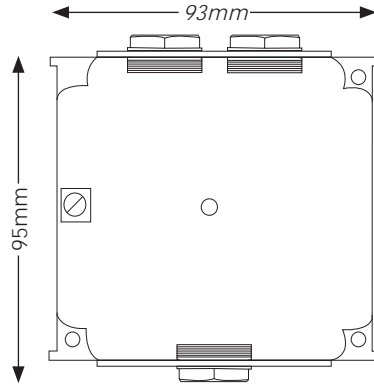

Fig 1 Backbox

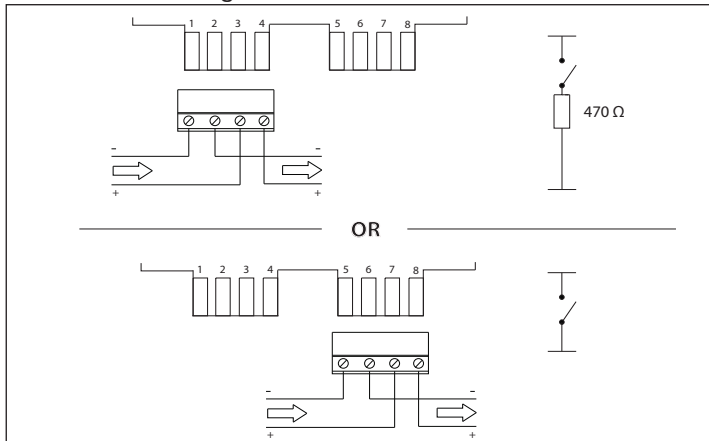

Fig 2 Terminal block connections

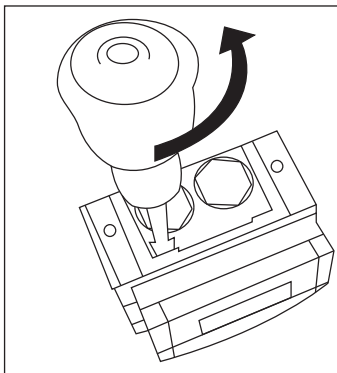

Fig 3 Cover removal

## Troubleshooting

Before investigating individual units for faults, it is important to check that the system wiring is fault free.

Many fault conditions are the result of simple wiring errors. Check all connections to the unit.

### General Fault Finding

Problem	Possible Cause
Control panel reports zone fault	Incorrect zone wiring Detector removed
Control panel reports alarm	EOL device missing or incorrectly fitted MCP not reset Test key not removed
MCP does not activate alarm	Incorrect EOL device Incorrect wiring Incompatible control panel

### Routine testing

Insert the test key into the hole at the bottom of the call point and push home. Observe routine test requirements as specified in the applicable local codes. Apart from regular testing, as part of the scheduled maintenance of the fire alarm system, no additional maintenance is required.

### Resetting

After testing, reset the call point by removing the test key and pushing up the front cover until it clicks home.

### Earthing

An earthing plate is provided for continuity of metal conduits. This must be placed behind the back box prior to fixing the box to the wall. Fit the three M20 nylon washers between the earthing plate and the backbox before fitting cable glands, conduit or blanking plugs.

### Important Information

The use of lubricants, cleaning solvents or petroleum based products should be avoided. The O-ring should be replaced when refitting or replacing the Waterproof cover.

For further information refer to PP2418.

### Transparent hinged cover

To provide additional protection against accidental operation, a transparent hinged cover, part no 26729-152, is available.

To prevent against malicious activations of call points, locking tags are also available, part no. 26729-179 (pack of 5).

Please note that the call point does not conform to EN54-11 : 2001 when the hinged cover is secured with the locking tag.

These call points carry the following approvals:

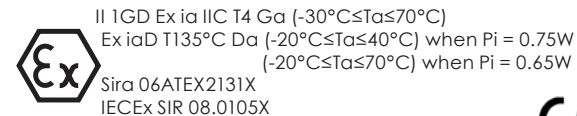

They are designed and manufactured to protect against other hazards as defined in paragraph 1.2.7 of Annex II of the ATEX Directive 94/9/EC.